

# INSTRUCTIONS AND REPAIR PARTS LIST

**11H SINGLE DOOR FEEDER  
1HF DRY LOT FEEDER  
22H TWO DOOR FEEDER  
2HF DRY LOT FEEDER**

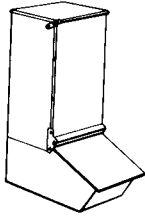

11H Single Door Feeder

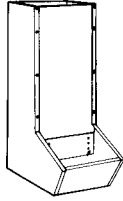

1HF Dry Lot Feeder

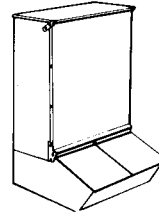

22H Two Door Feeder

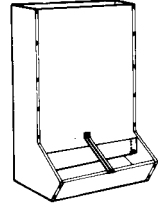

2HF Dry Lot Feeder

## **READ ALL DIRECTIONS CAREFULLY BEFORE BEGINNING INSTALLATION**

**TOOLS REQUIRED:** Straight Blade Screwdriver, Phillips Head Screwdriver, Small Adjustable Wrench, Center Punch

**REPAIR PARTS LIST FOR 11H AND 1HF - See Exhibit A on page 4 for location of parts**

Ref. No.	Part No.	Description	Quantity
1	13886	Top	1 (0)
2	13868	Back and Sides	1
3	13869	Front	1
4	13884	Lid	1 (0)
5	13887	Lower Panel	1
6	13888	Feed Slide Adjustment	1
7	OF228	1/4-20 x 5/8 Indented Sheet Metal Screw, Zinc	2
8	13867	Trough Assembly (Note: The three (3) parts designated as Ref. No. 8 are available only as riveted assembly No. 13867)	1
9	13883	5/16 x 12 1/2 Lid Rod, Zinc	2 (0)
10	OF78 *	1/8 x 3/4 Steel Cotter Pin, Zinc	2 (0)
11	13885 *	Top Hinge	2 (0)
12	13882 *	Lid Rod Holder	2 (0)
13	OF160 *	5/16 - 18 Cold Forged Wing Nut, Zinc	2 (2) **
14	OF121 *	3/8" ID x 7/8" OD Washer, Zinc - 5/16	4 (0)
15	OF55 *	1/4 - 20 Hex Nut, Zinc	26 (24) **
16	OF182 *	1/4 - 20 x 1/2 Phillips Pan Head Machine Screw, Zinc	26 (24) **
	13881	Hardware Bag, for 11H, Includes items with *	1
	11811	Hardware Bag for 1HF, includes items with **	1
	70761	Brower Decal, 6 3/4 x 4	1
	ISB11H22H	Instruction Sheet	1

Under Quantity column, numbers in ( ) are for 1HF.

### **MODEL NUMBER**

The MODEL NUMBERS are: 11H Single Door Feeder, 1HF Dry Lot Feeder, 22H Two Door Feeder, 2HF Dry Lot Feeder

### **WHEN ORDERING PARTS**

- (1) Show MODEL NUMBER and NAME: Example - 11H Single Door Feeder
- (2) Show PART NUMBER and FULL DESCRIPTION of part: Example - 13886 Top

### **HOW TO ORDER PARTS**

Repair parts may be ordered from your dealer.

**EXHIBIT B**

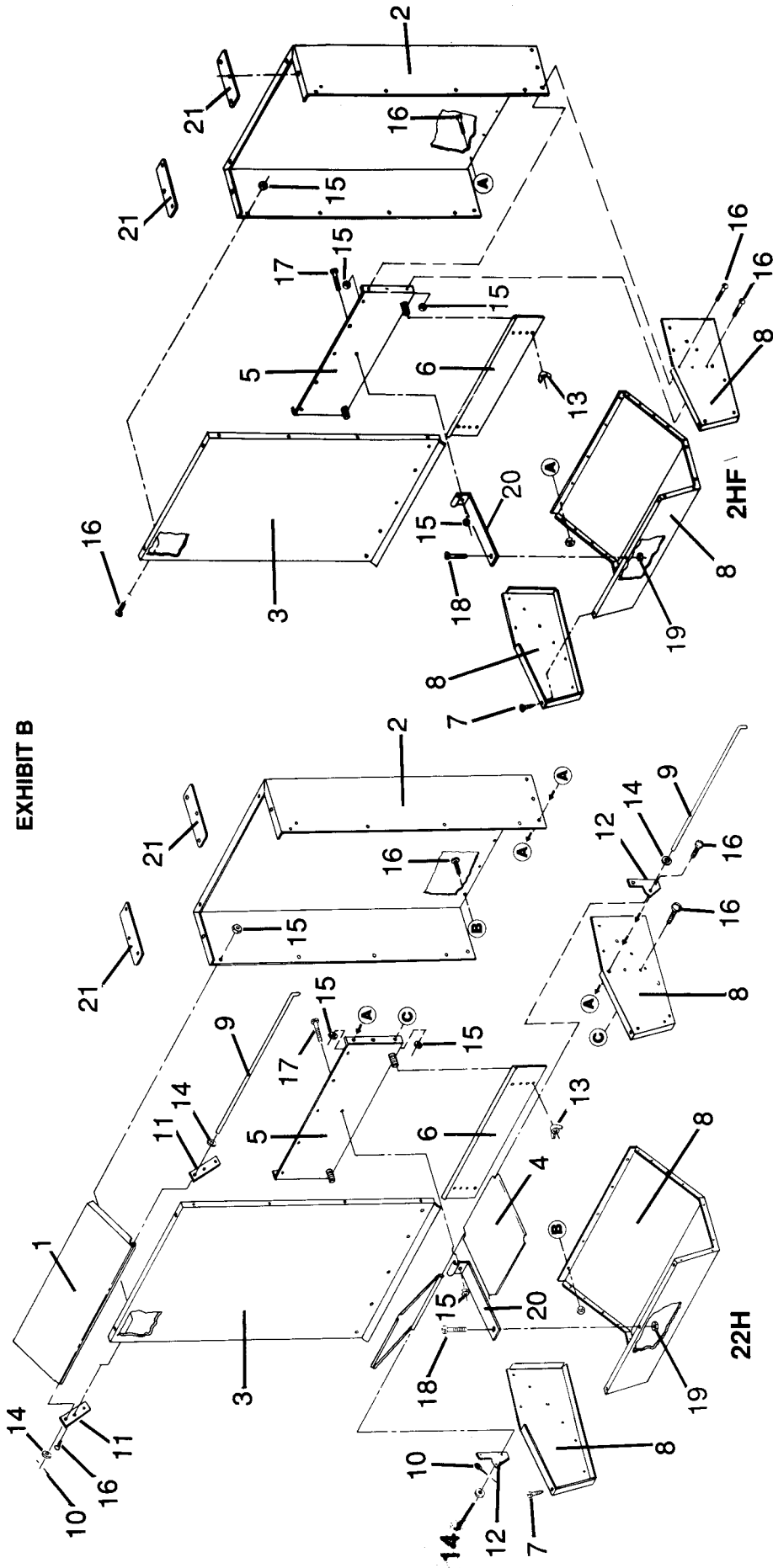

**INSTALLATION INSTRUCTIONS**

For Model 22H, follow steps 1 through 10. For Model 2HF skip steps 4, 8 and 9.

**STEP 1:** Attach the back and sides of hopper (Ref. No. 2) to the trough assembly (Ref. No. 8) placing the hopper on the outside of the trough. Insert only the back bolts (Ref. No. 16).

**STEP 2:** Install the lower panel (Ref. No. 5) by inserting only the bottom 2 bolts on both sides.

**STEP 5:** Position red trough divider (Ref. No. 20) using the smallest bolt and nut on the trough lip (Ref. No. 18 and 19). Insert the 1/4-20 x 3/4 screw (Ref. No. 17) into the center hole in the lower panel (Ref. No. 5). Tighten both the front and the rear bolts on the trough divider.

**STEP 6:** Position the corner braces (Ref. No. 21) on the underside of the hopper lip.

**STEP 7:** Install the feed slide adjustment (Ref. No. 6) and secure with 2 wing nuts (Ref. No. 13).

STEP 3: Assemble the front panel (Ref. No. 3) to the hopper back and sides (Ref. No. 2) inserting only the center 2 bolts on both sides and all of the front bolts.

STEP 8: Install the hopper cover (or top) and insert hinge rod (Ref. No. 9), washers (Ref. No. 14) and cotter pin (Ref. No. 10).

STEP 4: Place the top hinges (Ref. No. 11) in place before inserting top bolts on the front panel (Ref. No. 3). Insert the second bolt in place on the top hinge. Position lid rod holders (Ref. No. 12) in position and put remaining bolts in place. Now tighten all bolts that you have installed.

STEP 9: Likewise position trough covers (Ref. No. 4) with hinge rod, washers and cotter pin.

STEP 10: Check to make sure that all fasteners are secured. Your feeder is ready for use. The feed slide adjustment height can be changed as you desire.

## REPAIR PARTS LIST FOR 22H AND 2HF - See Exhibit B on page 2 for location of these parts

Ref. No.	Part No.	Description	Quantity
1	13895	Top	1 (0)
2	13899	Back and Sides	1
3	13894	Front	1
4	13884	Lid	2 (0)
5	13898	Lower Panel	1
6	13897	Feed Slide Adjustment	1
7	OF228	1/4 - 20 x 5/8 Indented Sheet Metal Screw, Zinc	2
8	13878	Trough Assembly	1
(Note: The three (3) parts designated as Ref. No. 8 are available only as Riveted Assembly No. 13878.)			
9	13892	5/16 x 24 1/4 Lid Rod, Zinc	2 (0)
10	OF78 *	1/8 x 3/4 Cotter Pin, Zinc	2 (0)
11	13885 *	Top Hinge	2 (0)
12	13882 *	Lid Rod Holder	2 (0)
13	OF160 *	5/16 - 18 Cold Forged Wing Nut, Zinc	2 (2)**
14	OF121 *	3/8" ID x 7/8" OD Washer, Zinc - 5/16	4 (0)
15	OF55 *	1/4 - 20 Hex Nut, Zinc	37 (29)**
16	OF367	6-32 x 1/2 Slotted Round Head Machine Screw, Zinc	36 (29)**
17	OF11 *	1/4 - 20 x 3/4 Slotted Round Head Machine Screw, Zinc	1 (0)
18	OF214 *	10 - 24 x 1/2 Slotted Round Head Machine Screw, Zinc	1 (1)**
19	OF53 *	10 - 24 Hex Machine Screw Nut, Zinc	1 (1)**
20	9319	Trough Brace	1
21	11839	Corner Brace	2
	13891	Hardware Bag for 22H includes items with *	1
	11821	Hardware Bag for 2HF includes items with **	1
Note that quantities in brackets are in 11821 Hardware Bag			
	70761	Brower Decal 6 3/4 x 4	1
	ISB11H22H	Instruction Sheet	1
Under Quantity column, numbers in ( ) are for 2HF.			

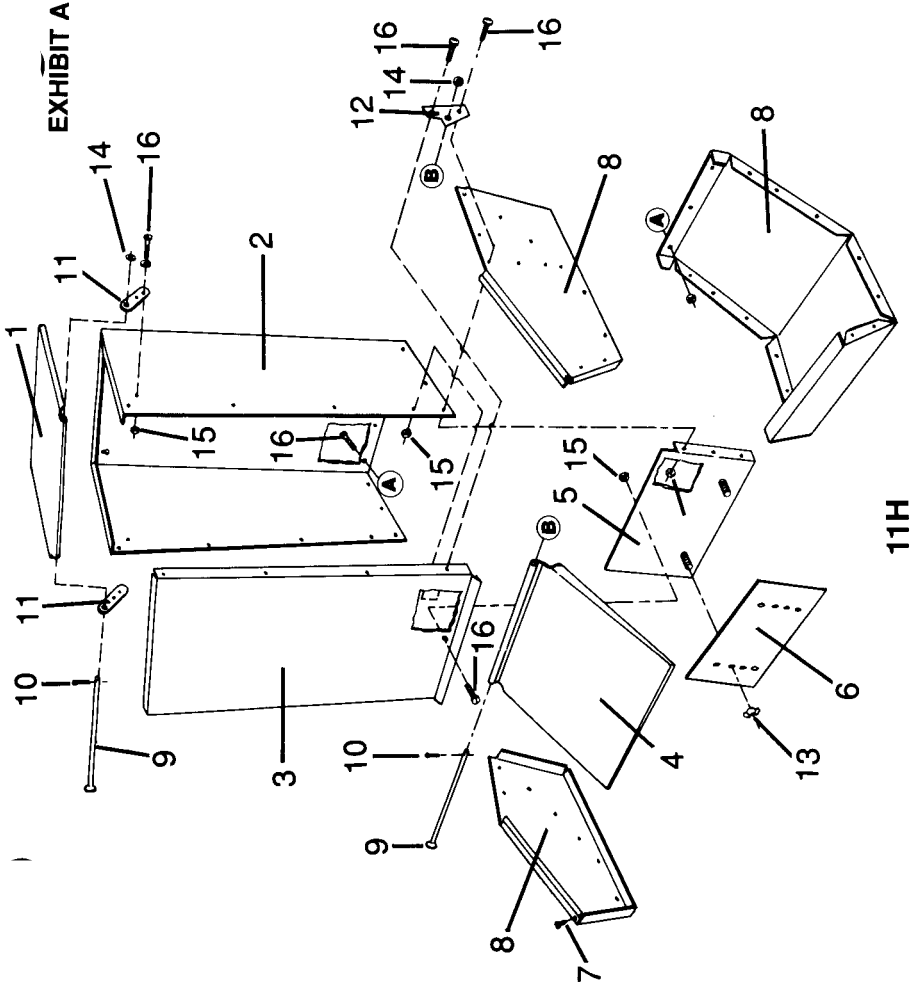

**INSTALLATION INSTRUCTIONS**

**DO NOT TIGHTEN ANY FASTENERS UNTIL INSTRUCTED TO DO SO!**

- For Model 11H, follow steps 1 through 8. For Model 1HF, skip steps 4, 6 and 7.
- STEP 1:** Attach the back and sides of hopper (Ref. No. 2) to the trough assembly (Ref. No. 8) placing the hopper on the outside of the trough. Insert only the back bolts (Ref. No. 16).
- STEP 2:** Install the lower panel (Ref. No. 5) by inserting only the bottom 2 bolts on both sides.
- STEP 3:** Assemble the front panel (Ref. No. 3) to the hopper back and sides (Ref. No. 2) inserting only the center 2 bolts on both sides and all of the front bolts.
- STEP 4:** Place the top hinges (Ref. No. 11) in place before inserting top bolts on the front panel (Ref. No. 3). Insert the second bolt in place on the top hinge. Position lid rod holders (Ref. No. 12) in position

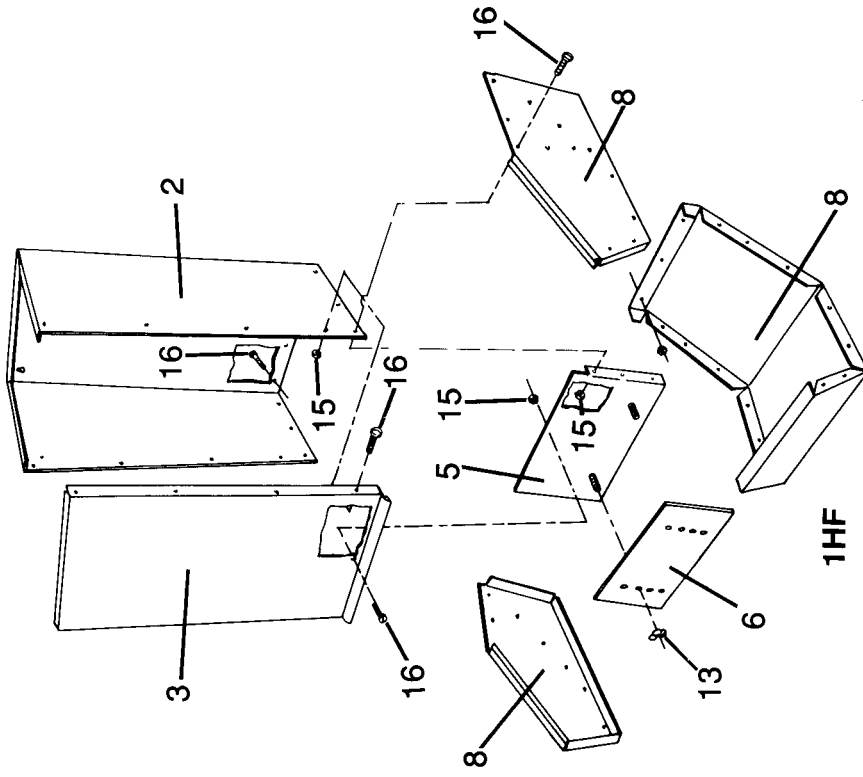

- and put remaining bolts in place. Now tighten all bolts that you have installed.
- STEP 5:** Install the feed slide adjustment (Ref. No. 6) and secure with 2 wing nuts (Ref. No. 13).
- STEP 6:** Install the hopper cover (or top) and insert hinge rod (Ref. No. 9), washers (Ref. No. 14) and cotter pin (Ref. No. 10).
- STEP 7:** Likewise position trough lid (Ref. No. 4) with hinge rod, washers and cotter pin.
- STEP 8:** Check to make sure that all fasteners are secured. Your feeder is ready for use. The feed slide adjustment height can be changed as you desire.