

INSTRUCTIONS AND REPAIR PARTS LIST

2G GRO-FAST™ HOG FEEDER

READ ALL DIRECTIONS CAREFULLY BEFORE BEGINNING INSTALLATION

TOOLS REQUIRED: Straight Blade Screwdriver, Phillips Screwdriver, Adjustable Wrench or 7/16" Wrench, Center Punch. Assembly time is about one hour. One person assembly is possible, but some steps go a lot better with an additional helper.

REPAIR PARTS LIST - See Exhibit A on page 3 for location of parts

Ref. No.	Part No.	Description	Quantity
1	17434	Top Cover Assembly, 2G	1
2	9313	Hinge, 2G	2
3	9231	Corner Brace, 2G	4
4	9344	Back Panel, 2G	1
5	9344F	Front Panel, 2G (has slot for handle latch)	1
6	9227	Hopper Side	2
NOTE: The preassembled trough part number is 9341. 9341 consists of Ref. Nos. 7, 8, 11 and 18.			
7	9238	Trough End	2
8	9342	Trough Bottom	1
9	9232	End Brace Angles (for Lid Rods)	2
10	17435	Lower Side Panel Assembly (Front and Back)	2
11	9259	Trough Angle Brace	4
12	9319	Trough Brace (painted red)	2
13	13884	Lid	4
14	13892	5/16 x 24 1/4 Lid Rod, Zinc	2
15	9326	Feed Adjustment Panel	2
16	OF214*	10-24 x 1/2 Slotted Round Machine Screw, Zinc	2
17	OF53*	10-24 Hex Machine Screw Nut, Zinc	2
18	OF228	1/4 -20 x 5/8 Indented Hex Sheet Metal Screw, Zinc	4
19	OF160*	5/16 -18 Cold Forged Wing Nut, Zinc	4
20	OF78*	1/8 x 3/4 Cotter Pin, Zinc	5
21	9307*	Handle Clip	1
22	F60C84*	Handle Latch	1
23	71753*	Handle	1
24	OF16*	1/4 x 9/16 Clevis Pin, Zinc	3
25	OF120*	1/4 Flat Washer, Zinc	8
26	OF121*	5/16 Flat Washer, Zinc	8
27	OF55*	1/4 - 20 Hex Nut, Zinc	64
28	OF182*	1/4 - 20 x 1/2 Phillips Pan Head Machine Screw, Zinc	64
29	OF113*	1/4 Split Lockwasher, Zinc	66
	9334	Hardware Bag for 2G, includes items with *	
	ISB2G	Instruction Sheet	1
	70762	Decal, Brower, 4 3/4 x 19 7/8	

MODEL NUMBER

The MODEL NUMBER is: 2G Gro-Fast™ Feeder

WHEN ORDERING PARTS

- (1) Show MODEL NUMBER and NAME: Example - 2G Feeder
- (2) Show PART NUMBER and FULL DESCRIPTION of part: Example - 13884 Lid

HOW TO ORDER PARTS

Repair parts may be ordered from your dealer.

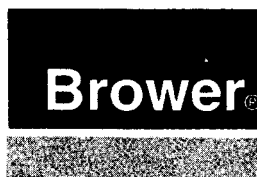

EQUIPMENT FOR POULTRY • LIVESTOCK • PETS
 PO BOX 2000 • HOUGHTON, IOWA 52631 USA
 PHONE 319-469-4141 • FAX 319-469-4402
 E-mail: broweriowa@aol.com • Web: www.browerequip.com

ASSEMBLY INSTRUCTIONS

DO NOT TIGHTEN ANY FASTENERS UNTIL INSTRUCTED TO DO SO!

When assembling this feeder, the side from which the lid is raised will be considered as the front and the right and left ends will be determined when facing the front.

- STEP 1: Attach lower side panel assembly (front and back) marked as Ref. No. 10 to trough angle braces (Ref. No. 11). Ref. No. 10 is mounted so that the pre-welded bolt threads face outwardly toward you and with the threads on the lower side. Also, Ref. No. 10 goes on the inside of Ref. No. 11 bracket. Ref. No. 10 panel is mounted through the second hole from the bottom on Ref. No. 11 brace. Note C on Exhibit A. Repeat for both panels.
- STEP 2: Attach hopper sides (Ref. No. 6) to the front and back panels (Ref. Nos. 4 and 5). The sides (Ref. No. 6) go out and over the front and back panels. Bolt and finger tighten all hopper section fasteners except for the bottom 4 corners. These holes will be used to mount the hopper to the trough as explained below, use fasteners Ref. Nos. 27, 28, 29.
- STEP 3: This step will probably be facilitated with a second helper as the bolts may be hard to reach. Lift the partially assembled hopper onto the trough. The hopper edges go out and over the trough edges. Align the bottom holes in the hopper and the top holes on the trough angle (Ref. No. 11). Note A - B on Exhibit A. Fasten each hopper corner to the trough angle. Also a fastener goes in the center hopper hole (toward the bottom edge) and through the lower side panel assembly (Ref. No. 10) on each side.
- STEP 4: Locate the end brace angles, painted red (Ref. No. 9). Ref. No. 9 is mounted with the holes against the trough and down. Note position of Ref. No. 9 on Exhibit A. Using a center punch, align the holes that go through the angle (Ref. No. 9), the hopper side (Ref. No. 6) and the trough end (Ref. No. 7). Insert all 4 fasteners using lockwashers and nuts (Ref. Nos. 27, 28, 29). Repeat on the other side.
- STEP 5: Tighten all fasteners which have been inserted at this time.
- STEP 6: Locate the feed adjustment panel (Ref. No. 15). Mount the panel on the pre-welded bolts on the lower side panel assemblies (Ref. No. 10). Use $\frac{5}{16}$ " flat washers and wing nuts (Ref. Nos. 26 and 19).
- STEP 7: Attach trough brace, also painted red (Ref. No. 12) to the trough lip with the small bolt, lockwasher and nut (Ref. Nos. 16, 17, 29). Also attach trough brace to the lower side panel assembly (Ref. No. 10) using a larger $\frac{1}{4}$ -20 screw, lockwasher and nut. Repeat on the other side. Do not tighten any of these fasteners until after STEP 8 is complete.
- STEP 8: Locate trough lids (Ref. No. 13) and lid rods (Ref. No. 14). Place one $\frac{5}{16}$ " washer (Ref. No. 26) on a lid rod. Put the rod through the holes on the end brace angle (Ref. No. 9). Push rod through the first lid, through the center trough brace (Ref. No. 12), then through the second lid, and finally through the hole on the opposite end brace angle. Add another $\frac{5}{16}$ " washer and secure with a cotter pin (Ref. No. 20). Repeat on the other side. Now tighten the fasteners on the trough brace (Ref. No. 11).
- STEP 9: Locate the handle latch (Ref. No. 22) and mount on the front panel using 1 clevis pin (Ref. No. 24), 4 $\frac{1}{4}$ " washers (Ref. No. 25) and a cotter pin (Ref. No. 20). See Exhibit A for how these are mounted. You will need to adjust the latch before you begin using the feeder.
- STEP 10: Mount the handle (Ref. No. 23) to the cover (Ref. No. 1) as shown in Exhibit A. Then assemble both hinges (Ref. No. 2) to the cover as shown on Exhibit A. Tighten these fasteners.
- STEP 11: Locate the 4 corner braces (Ref. No. 3). Assemble these braces to the top of the hopper and tighten. (The braces mount on top of the lip).
- STEP 12: Take the cover assembly and mount on top of the hopper with the latch handle to the front. Attach the cover to the hopper using clevis pins (Ref. No. 24), two $\frac{1}{4}$ " washers (Ref. No. 25) and a cotter pin (Ref. No. 20) on each side. See Exhibit A for washer placement.
- STEP 13: Set the feeder on a level surface and make sure that your assembly is square. Now double check to see that all fasteners are tight. Extra hardware may remain. Your feeder is now ready for use.

OPERATING INSTRUCTIONS

The adjustments (Ref. No. 15) at the bottom of the feed trough may be adjusted for various kinds of feed. Always keep the adjustments low enough so that the troughs are only partly full. This will minimize feed waste.

Should feed become caked or bridged in the hopper, simply lift the lid and loosen feed until it flows freely. This will not be necessary unless the feed becomes damp.

CAUTION: Do not attempt to move feeder when full of feed.

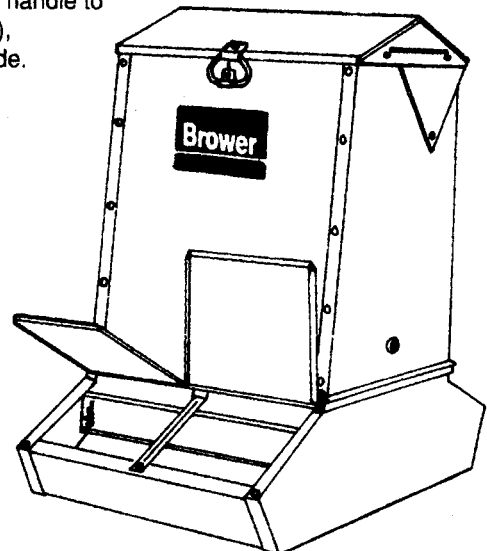

EXHIBIT A

