

# INSTRUCTIONS

## REPAIR PARTS LIST AND WARRANTY INFORMATION



### READ ALL INSTRUCTIONS CAREFULLY BEFORE BEGINNING INSTALLATION

Models WPO1E and MPO1E come equipped with a heater. Models WPO1N and MPO1N do not come with a heater. If you have ordered WPO1N or MPO1N and want to add a heater, order Model OP284P Utility De-Icer.

**REPAIR PARTS LIST** - See Exhibits E, F, G, H and I for location of parts.

Ref. No.	Part Number	Description	Qty
1	WPO150	Drinker Base, Blue	1
1	MPO150	Drinker Base, Red	1
1	GPO150	Drinker Base, Green	1
2	WPO112	Bottom Cover, Stainless Steel	1
3	WPO111	Top Cover, Stainless Steel	1
4	OF514	1/4-20 x 1/2 Slotted Indented Washer Head Machine Screw	4
5	WPO116	3/4" X 6 1/4" Stand Pipe, PVC	1
6	OP325	3/4" O-Ring	1
	<b>WPO114</b>	<b>Hardware Bag Assembly (Includes Ref. Nos. 7 through 14)</b>	
7	OP301	Inner Drain Plug	1
8	OP120	Outer Drain Plug	1
9	OP303	Drain Line, 3/4" x 18"	1
10	WPO113.A	Water Supply Line, 1/4" x 36"	1
11	OP124	Clamp, 1/4" - 5/8, SS	1
12	VT100	Float Valve	1
13	OP284P	C250 Utility De-Icer	1
14	ISHBSD	Instruction Sheet	1

### MODEL NUMBER

The MODEL NUMBERS are: WPO1BE, WPO1BN, WPO1RE, WPO1RN, WPO1GE, WPO1GN, MPO1BE, MPO1BN, MPO1RE, MPO1RN, MPO1GE, and MPO1GN.

NOTE: The letters B, R, and G denote colors with B=Blue, R=Red, and G=Green.

### WHEN ORDERING PARTS

- (1) Show MODEL NUMBER and NAME: Example - WPO1RE Poly Drinker
- (2) Show PART NUMBER and FULL DESCRIPTION of part: Example - OP120 Outer Drain Plug



# WATER AND ELECTRICAL LINE INSTALLATION

Review Exhibits A, B, C, and D. Decide how your water supply line and electrical line (if using heater) will enter the drinker

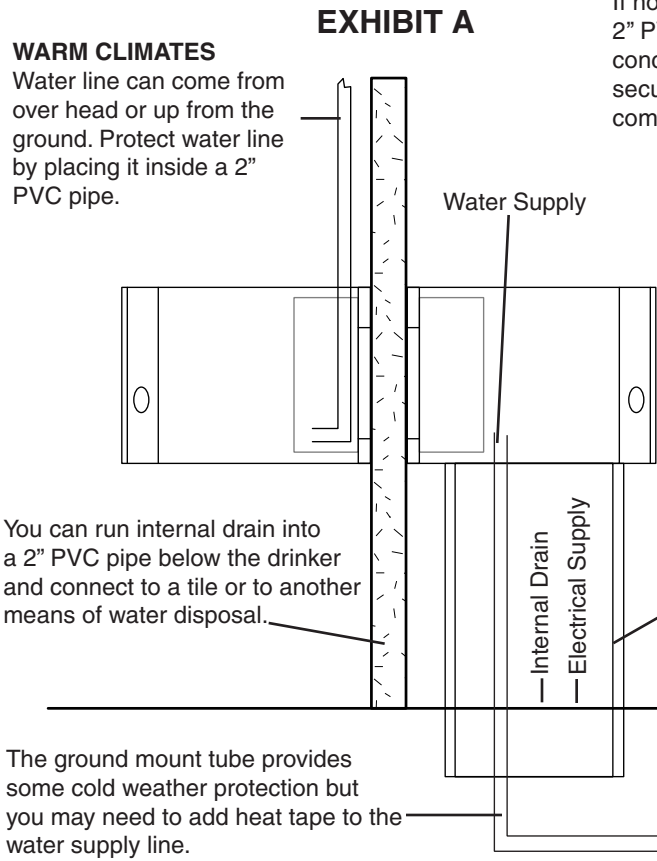

If not using ground mount tube, run 2" PVC pipe about 1" or so into this concaved area. This will give you a secure installation whether you are coming from above or from below.

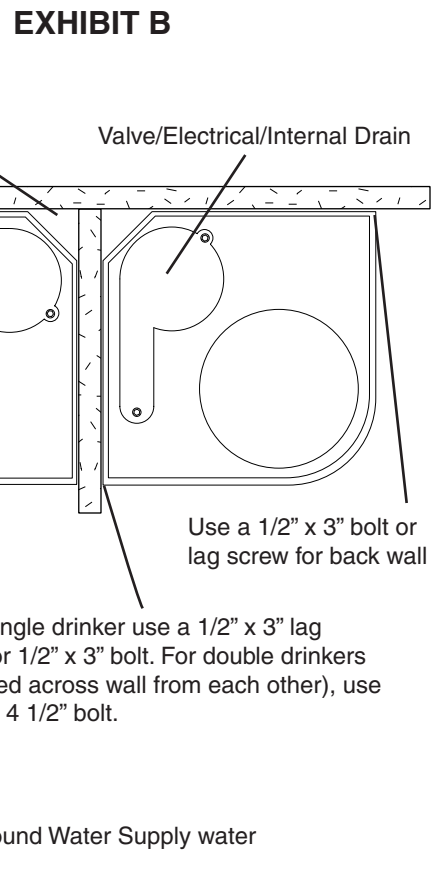

For cold climate installations, our Model HT10 ground mount tube is an option. The heat tube is designed to mate with the cavity under the drinker base. You should use silicon caulk to assure an airtight fit. Both the water line and the electrical supply can enter from below.

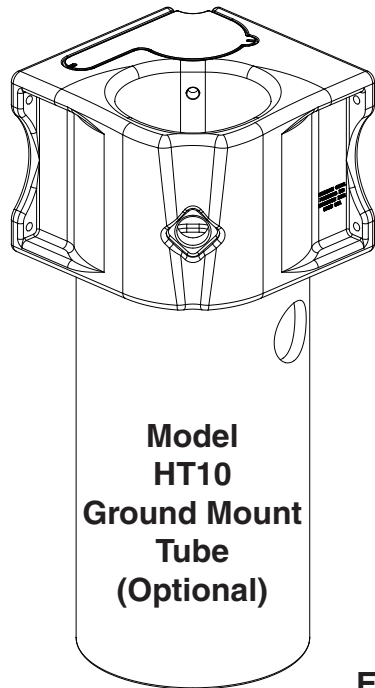
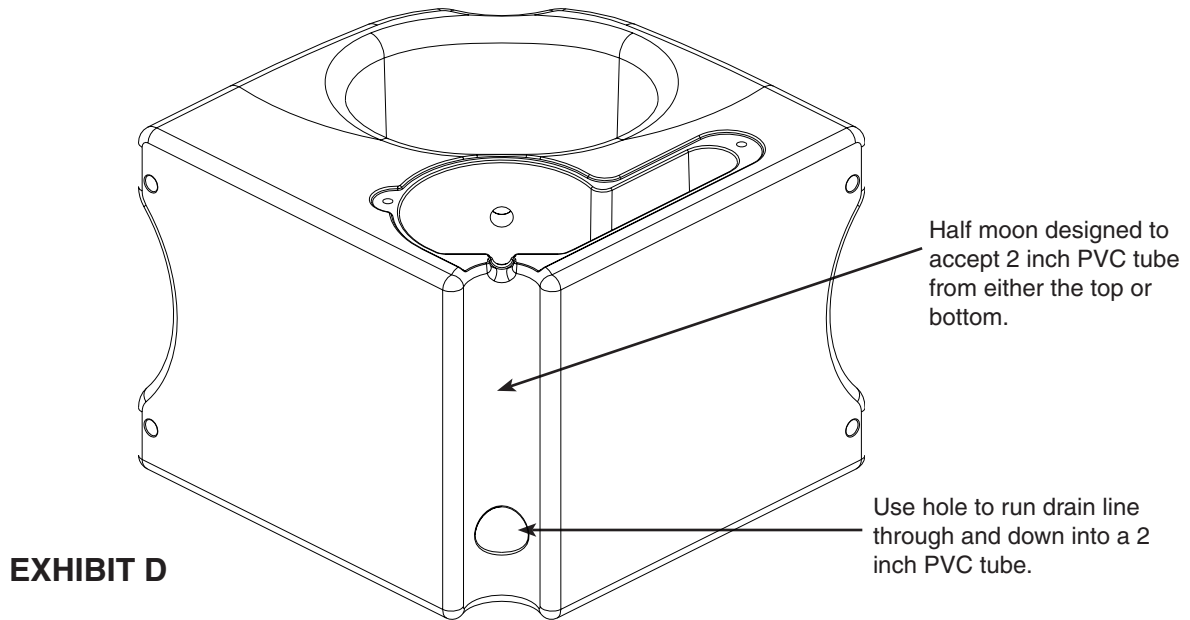

**EXHIBIT C**

For warm climate installations, the water line can come from above or below. It should be protected inside of a 2" PVC tube or by some other means of protection. Please note that the half moon area at the rear corner of the drinker base is designed to accept a 2" diameter PVC tube. See Exhibit D.

## DECIDE HOW YOU WANT TO DRAIN THE DRINKER FOR CLEANING

For warm climate installations, when you clean the drinker, you can use the outer drain and drain into a bucket. Also, the 3/4" drain line (Ref. No. 9) is flexible enough to be run through the rear corner lower hole and drain into a tile under the stall if so desired. See Exhibit D.



## EXHIBIT E

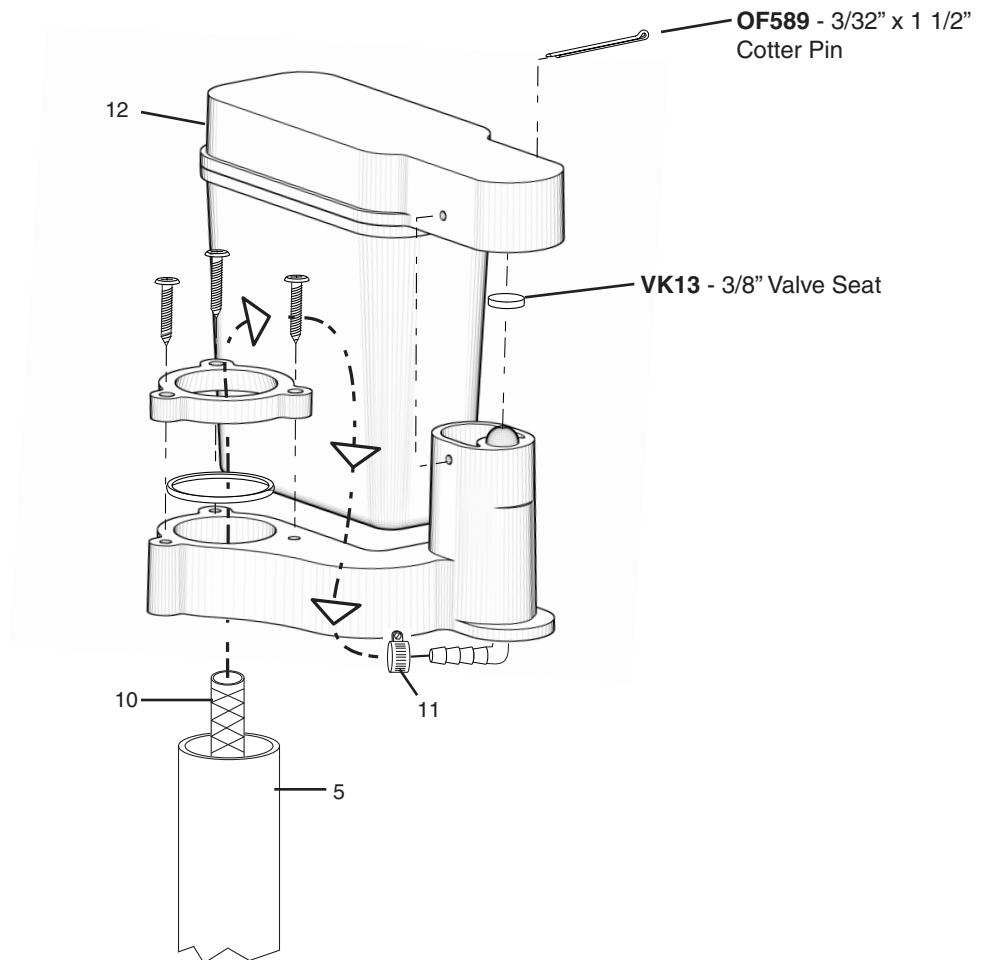

## INSTALLATION INSTRUCTIONS

1. Remove both top and bottom covers (Ref. Nos. 2 and 3).
2. Compare hardware bag contents with the parts list on page 1 to identify all parts.
3. Install drinker. Review Exhibit B. Use 1/2" x 3" lags or bolts (not supplied). If using bolts, but nuts on the inside. Distance from the floor is at users' direction.
4. Install outer and inner drain plugs (Ref. No. 7 and 8).
5. Run water supply line (Ref. No. 10) up through stand pipe (Ref. No. 5).

**Note: The easiest way to install valve is to connect water supply line first, then mount valve to stand pipe. See Exhibit E.**

6. Slip Ref. No. 11 hose clamp through the end of the supply line.
7. Attach supply line to the hose barb (which is already connected to the valve). Tighten Clamp.
8. Slide the valve onto the Ref. No. 5 stand pipe. Mount the valve at least 1 inch below the top of the stand pipe to begin with. Tighten by tightening three screws (see Exhibit E) around stand pipe mount on valve. Once water level is known, it can be fine tuned by moving the valve on the stand pipe.

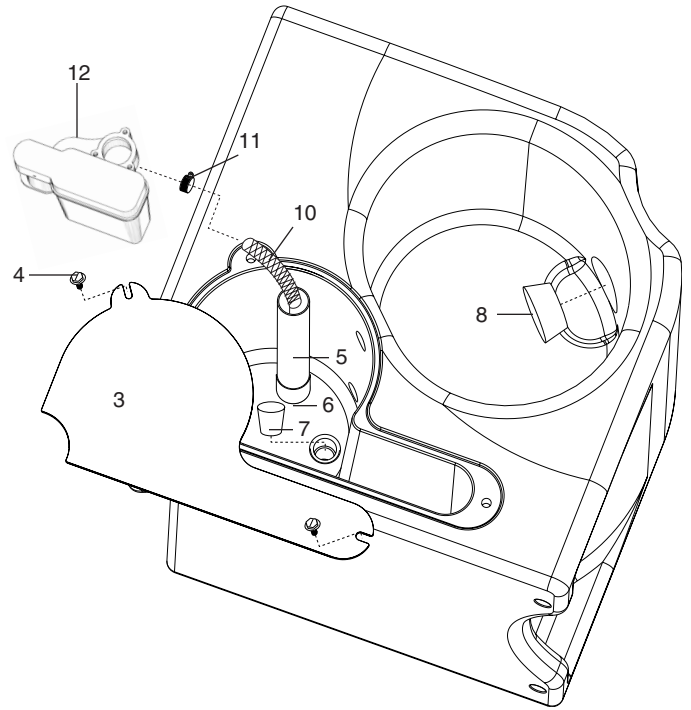

**EXHIBIT F**

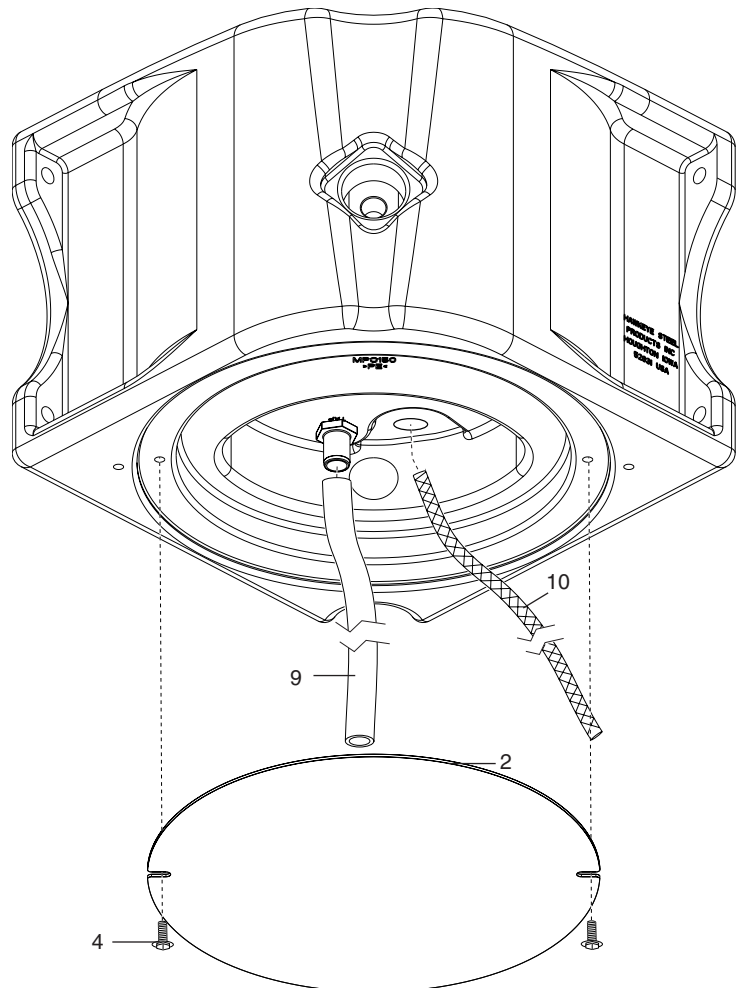

**EXHIBIT G**

## HEATER OPERATION AND MAINTENANCE

Your heater sets vertically in the cavity in the valve compartment. Run the cord through the slot at the top of rear corner. You can run the cord set through the hole at the bottom of the rear corner and into the ground mount tube or connection. See Exhibit G.

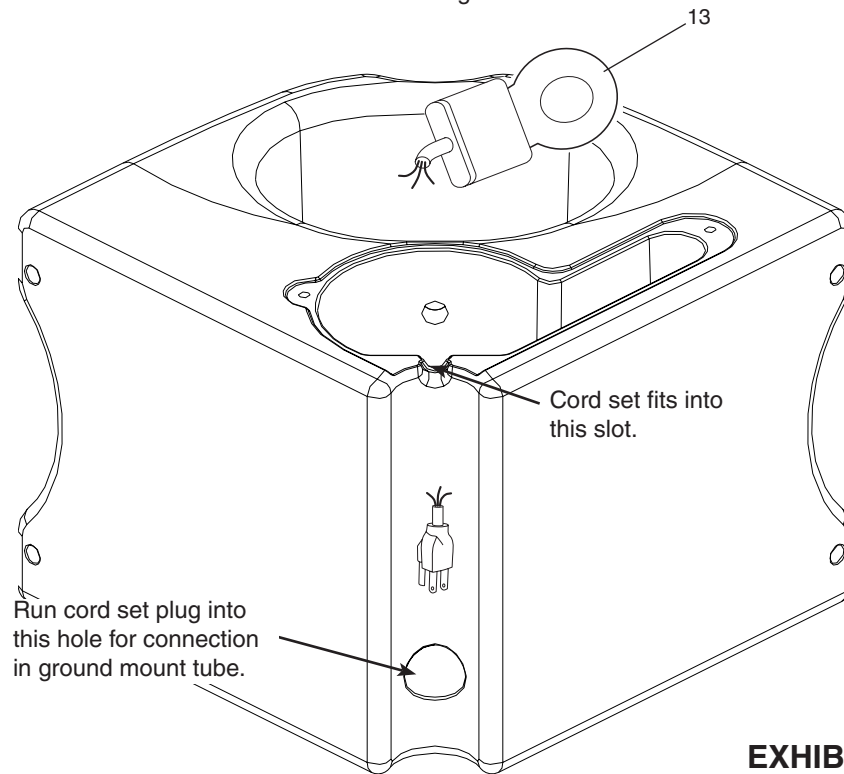

**EXHIBIT G**

Farm Innovators Model C250 Utility De-Icer standard specifications are 250 Watts / 120 VAC / 2.0 AMPS. The heat range is about 34° F to 45° F. The de-icer only works when the temperature approaches freezing. It is thermostatically controlled to turn on at freezing and to turn off when the temperature is above freezing.

If water freezes in the drinker due to the loss of power, allow unit adequate time to melt itself free. Do not chop or cut at unit while plugged in.

Low voltage is a possible cause for failure or poor performance. Measure voltage at receptacle with unit energized. Voltage drop means wattage reduction. Extension cords cause voltage drop and are unsafe.

**IMPORTANT! DO NOT ALLOW DEPOSITS TO BUILD ON THE HEATING ELEMENT.** This can cause "hot spots" which is a primary reason of failure and voids the warranty. White vinegar or "Lime Away" can be used to clean the tubular element.

When taking unit out of service, disconnect power supply cord, remove unit from tank, clean element (see above), store indoors.

### **ALSO PLEASE NOTE:**

1. Do not energize the heater until the drinker is filled with water.
2. Do not operate the unit out of water (except to test - See 3 below).
3. Here's how you can check to see if your heater is working--
  - a) Set unit in freezer for one hour or outside for one hour if temperature is below 35 degrees F.
  - b) Connect heater to an electrical source. Hold the heater by the cord set. Within seconds, the element should begin to heat. Listen for the thermostat to "click" off. Disconnect the unit. The unit is working properly.

## HEATER OPERATION



**⚠ WARNING ⚠**  
**DO NOT DEFEAT ELECTRICAL GROUND**  
**AFFORDED BY 3-PRONG POWER CORD ASSEMBLY.**

**DO NOT ATTEMPT TO REPAIR HEATER.**

### OUTDOOR USE - See Exhibit I

This drinker can be used outside (heated or non-heated). In cold weather climates, we recommend that you mount on our optional Model HT10 Ground Mount Tube. Use of silicon caulking will give you an airtight connection. The tube can be set in concrete. You can cut it to a different length if you desire. Note that one end mates with the drinker so do not cut off that end. Use 2 locking tabs which mount to the bottom of the drinker base. The tabs interlock with the tube. The tube can be installed in the ground with the height at the users' discretion. The ground mount tube comes with 2 - WPO115 Locking Tabs, and 2 - Ref. No. 4, OF514, 1/4-20 x 1/2 Slotted Hex Head Screws, SS. HT10 also includes Part No. OP311, a 4 inch plastic hole plug. You may also need Model WPO116, a 2 inch PVC pipe protective assembly, needed to cover the power cord. If you are installing outdoors in a colder climate, you will need to add heat tape to your supply line inside the ground mount tube.

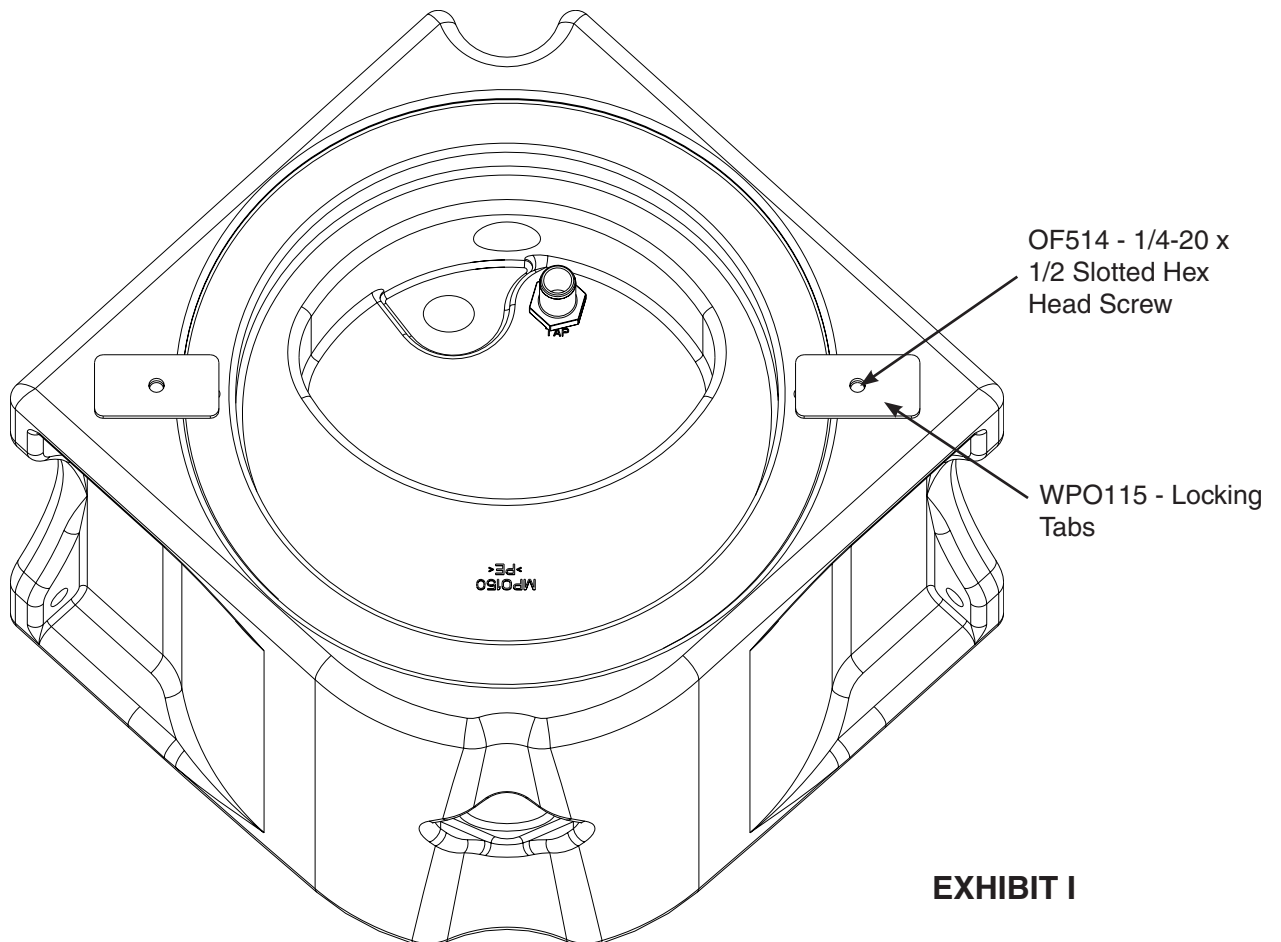

**EXHIBIT I**

## LIMITED WARRANTY

Our part no. OP284P C250 Utility De-icer (heater) and our VT100 Float Valve carry an 18 month limited warranty. All other components of Hawkeye Steel Products, Inc. Performance One E-Drinks are covered by a five year unconditional warranty and an additional 6 year prorated warranty. Both warranty periods are from the date of purchase. Each drinker must be registered with Hawkeye Steel Products, Inc. on the card which accompanies each drinker. Warranted components should be returned to your dealer for shipment to our factory -- Highway 16 West, P.O. Box 2000, Houghton, IA 52631 USA, Fax 319-469-4402; 800-553-1791. Warranty is limited to the repair or replacement of components. The warranty does not cover removal or reinstallation; cost to transport and retrieve components for repair; damage or loss occurring during transport; damage due to foundation design; damage caused by natural or environmental conditions (acts of God); costs associated with loss of time and/or inconvenience or any other consequential damages; injury; lack of animal performance; loss of profit; life or property, malfunction resulting from misuse; improper installation, lack of maintenance (such as periodically removing deposits on the de-icer), unauthorized alteration, or negligence. All provisions stated on the back of Hawkeye Steel Products, Inc.'s invoice apply and Hawkeye Steel Products, Inc. assumes no consequential damages.