

# INSTRUCTIONS

## REPAIR PARTS LIST AND WARRANTY INFORMATION

# WPO12E, WPO12N MPO12E, MPO12N POLY, ELECTRIC DRINKERS

**READ ALL DIRECTIONS CAREFULLY BEFORE BEGINNING INSTALLATION**



## WARNING



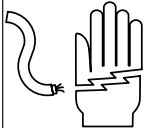

1. **INSTALLATION MUST BE MADE AND MAINTAINED IN STRICT ACCORDANCE WITH NATIONAL/LOCAL PLUMBING AND NATIONAL/LOCAL ELECTRICAL CODES (CSA IN CANADA). INSTALLATION MUST BE MADE BY A QUALIFIED ELECTRICIAN. THE APPLICABLE PROVISIONS OF THE ABOVE MENTIONED CODES TAKE PRECEDENT. IMPROPER ELECTRICAL INSTALLATION AND MAINTENANCE MAY RESULT IN SERIOUS INJURY OR DEATH FOR PERSONNEL OR LIVESTOCK.**
2. **EACH ELECTRICAL UNIT MUST BE WIRED THROUGH A FUSED SWITCH BOX AND FUSED ACCORDING TO AMPS REQUIRED FOR EACH SPECIFIED ELECTRICAL UNIT. SEE EXHIBIT A. CANADIAN ELECTRICAL CODE--PART 1 REQUIRES LIVESTOCK WATERERS INSTALLED IN FEEDLOTS IN OPEN FEEDING AREAS TO BE GROUNDED BY A SEPARATE STRANDED COPPER GROUNDING CONDUCTOR OF AT LEAST NO. 6 AWG TERMINATING AT A POINT WHERE THE BRANCH CIRCUIT RECEIVES ITS SUPPLY.**
3. **THIS UNIT MUST BE GROUNDED TO A COPPER GROUND ROD 5/8" (1.6CM) DIAMETER BURIED AT LEAST 10 FEET (3.1 METERS) IN UNDISTURBED SOIL. SEE EXHIBIT A.**

### REPAIR PARTS LIST - See Exhibit I on PAGE 6 for location of parts

Ref No.	Part Number	Description	Qty.	Ref No.	Part Number	Description	Qty.
1	WPO1710A	2 Hole Drinker Lid Assy, Pride of the Farm, Blue	1	12	WPO1218	Riser Tube Assembly, 11"	1
1	MPO1710A	2 Hole Drinker Lid Assy, Brower, Red	1	13	OP119	O-Ring, 1-3/4" ID x 2-1/8" OD x 3/16"	
2	WPO1211	2 Hole Drinker Base, Blue	1	14	OP116P	3/4" Schedule 40 Male Adapter, Standard, PVC	1
2	MPO1211	2 Hole Drinker Base, Red	1	15	OP120	#11 Rubber Stopper	1
3	WPO1213A	Door Assembly, Blue	1	16	OP210	1 1/2" NPT Plug, Plastic	1
3	MPO1213A	Door Assembly, Red	1	17	WPO1714	Base Seal, 84"	1
	WPO1217	Valve/Supply Line Assembly Hardware Bag includes Ref. Nos. 4 through 17 and the instruction sheet			WPO1216	Heater Assembly Hardware Bag Includes Ref. Nos. 18 through 24	
4	OP321	Float, Poly, 3 1/4" x 4 1/4" x 2 3/8"	1	18	WPO1219	1-1/2" x 12" Schedule 40 PVC	1
5	VA225P	Float Arm, 1/4-20 x 1, Plastic	1	19	OP118	1-1/2" MIP Adapter	1
6	VP115	Adjusting Screw, 1/4-20, Plastic	1	20	OP119	O-Ring, 1-3/4" ID x 2-1/8" OD x 3/16"	1
7	VP123	Valve Assembly, 5/32" Orifice	1	21	OP291	1-1/2" x 1-1/2" x 1" Slip Tee, Split	1
8	OP80	Elbow 3/4" x 3/4"	1	22	OP284P	C250 Utility De-Icer with Plug	1
9	OP116	3/4" Schedule 40 Male Adapter, Machined, PVC	1	23	OP93	11" Tywrap	2
				24	WPO256	Heat Tape (Not Shown)	1
10	OP117SJM	1-1/4" Slip Joint Nut	1	25	WT208	Foam Pipe Insulation, 36"	1
11	WPM112	3/4" PVC Pipe x 14 3/4" (Supply Tube)	1		ISHWPO12	Instruction Sheet	1

### MODEL NUMBER

The MODEL NUMBERS are: WPO12E, WPO12N, MPO12E, MPO12N Drinkers

### WHEN ORDERING PARTS

- (1) Show MODEL NUMBER and NAME: Example - WPO12E Poly Drinker
- (2) Show PART NUMBER and FULL DESCRIPTION of part: Example - OP210 1 1/2" NPT Plug, Plastic

### HOW TO ORDER PARTS

Repair parts may be ordered from your dealer.



## EXHIBIT A

**NOTE: Check local codes.**  
Some jurisdictions require 2 grounds & rods.

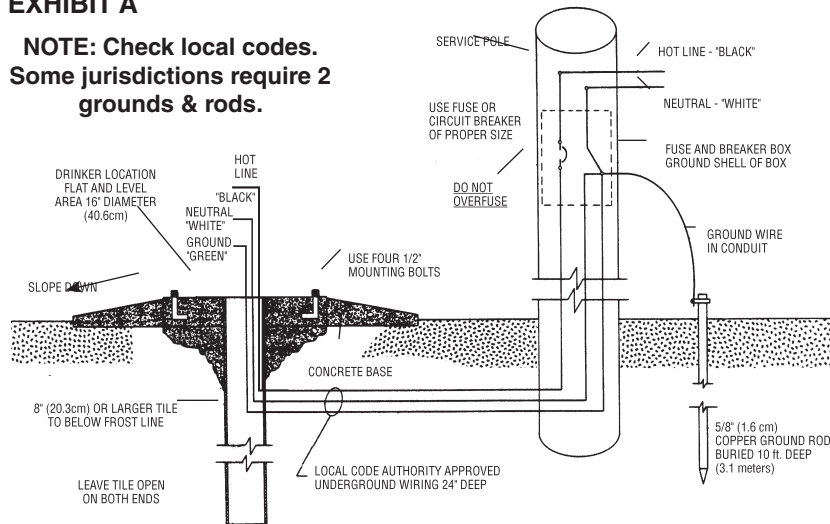

when protected as a feeder or branch circuit) and shall be buried at least 610mm (24 in.) below the ground surface. Wet rated conductors in non-metallic conduit are also acceptable for providing service.

5.2 Waterer installed near or in a building may be served by a branch circuit from the service equipment of the building.

## 6. Supply Circuits

6.1 Waterers installed within or near a building and served by a branch circuit from the service equipment of the building shall be connected as in Exhibit B.

6.1.1 The equipment grounding conductor shall originate at the service equipment of the building.

6.1.2 The equipment grounding conductor shall be connected to the equipment grounding terminal of the waterer and bonded to any intermediate enclosure or device that requires grounding. The equipment grounding conductor shall be isolated from the grounded (neutral) conductor at every point beyond service equipment.

6.2 An individual waterer installed in a lot and served by separate service equipment shall conform to the following: (see Exhibit C)

6.2.1 Overhead conductors shall be firmly attached to support points and conform to 5.1.1 and 5.1.2. Buried conductors shall conform to 5.1.3.

6.2.2 The incoming grounded conductor shall be bonded to the service equipment enclosure and to a grounding electrode conductor at the grounding bar in the service equipment. The grounding electrode conductor shall extend to a grounding electrode (a ground rod or other effective electrode).

6.2.3 An equipment grounding conductor shall originate at this service equipment and shall be installed with the circuit conductors to the waterer.

6.2.4 The equipment grounding conductor shall be installed as described in 6.1.2.

## 7. Multiple Installations

7.1 When more than one waterer is to be served from a central service, the service equipment should be located near the load center.

7.2 Each waterer shall be connected as specified in 6.2.

**NOTE: THE USE OF THE RISER PIPE AS A GROUNDING MEANS IS NOT RECOMMENDED**

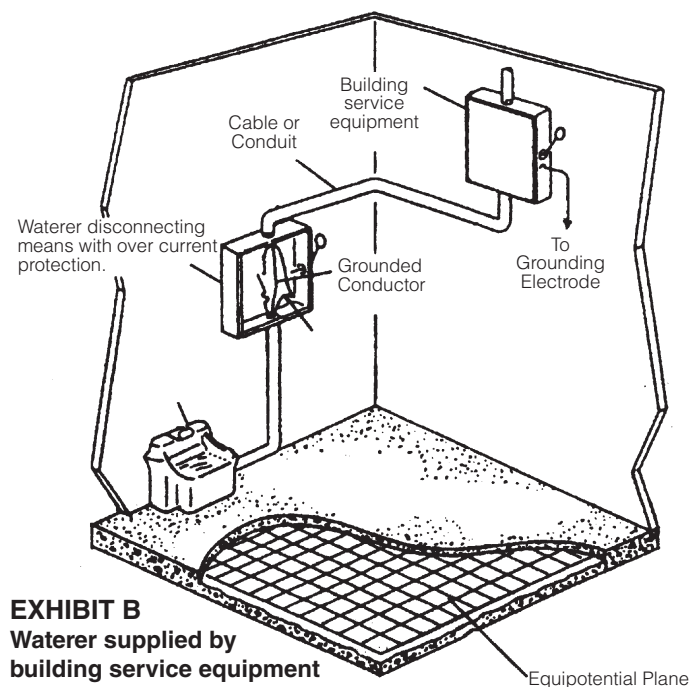

**EXHIBIT B**  
Waterer supplied by building service equipment

The following is intended to be used as a general guide for wiring electrically heated drinkers. Paragraph 5, 6, and 7 are taken from ASAE Engineering Practice: ASAE EP 342. Safety for Electrically Heated Livestock Waterers, March 1995. Installation can only be completed by a qualified electrician.

## 5. Electrical Service

5.1 Service conductors should conform to the following:

5.1.1 Conductors shall have sufficient ampacity for the load to be served.

5.1.2 Overhead conductors shall have mechanical strength for the distance spanned. The conductors shall not be smaller than NO. 8 American wire gage, AWG, copper or NO. 6 AWG aluminum or copper clad aluminum.

5.1.3 Buried connectors shall be of type USE (or UF

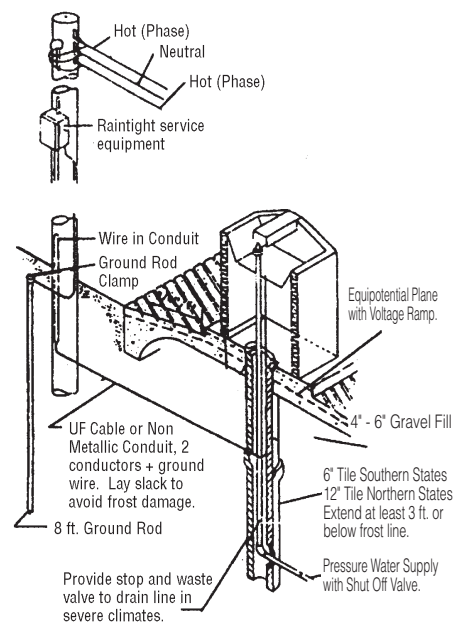

**EXHIBIT C**  
Waterer supplied by its own service equipment

## INSTALLATION INSTRUCTIONS

STEP 1: Get your qualified electrician involved in the planning of your installation.  
Review Exhibits A, B and C on page 2.

### STEP 2: RISER TILE

The ideal size of riser depends on the installation, source of water and geography. If you are replacing an existing waterer and have had no supply line freezing problems and have been using no supplemental heat on your supply line, you can probably use your existing tile as long as it is large enough to accommodate the insulated sleeve. (Ref No. 25). For best protection, we recommend that a new riser tile of at least 8 inches (20.3 cm) diameter be installed. **INSTALLATION MUST BE MADE WITHOUT THE SUPPLY LINE TOUCHING THE RISER TILE AND THERE MUST BE NO DEBRIS OR DIRT IN THE RISER TILE. DO NOT STUFF YOUR RISER TILE WITH INSULATION AS IT CAN BECOME WATER LOGGED RESULTING IN FROST PENETRATION.** If the installation is north of Interstate 90 or if frost heaving is a problem in your area, use a flexible supply line, such as 3/4 inch (1.9 cm) braided vinyl tubing available at most plumbing supply outlets. If your water supply line is flexible and you are concerned that the flex may cause it to touch the riser tile, use a deep well submersible cable guard (a nylon plate that slips over the supply line and keeps it centered). Ask for a deep well submersible cable guard at your local plumbing supply outlet. **BE SURE TO USE THE FOAM PIPE INSULATION PROVIDED AROUND YOUR SUPPLY LINE.** Make sure the insulation does not touch the riser tile as well.

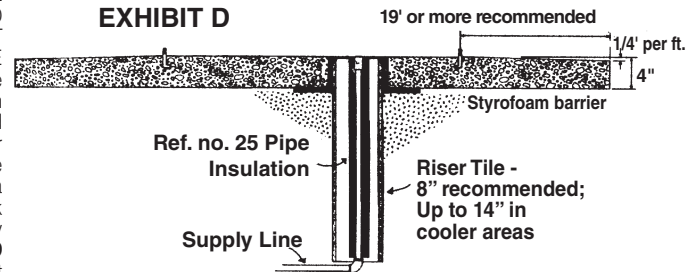

Where water is 54°F (12°C) or higher, you will probably not need to use a tile larger than 8 inches (20.3 cm) diameter. If entering water is 50°F(10°C) or colder, we recommend a tile of about 12 inches (30.5 cm) diameter. If incoming water has a temperature of the lower 40's (about 4°C), use a 14 inch (35.6 cm) tile.

### STEP 3: MOUNTING PAD - Review Exhibit D.

Concrete pad should be about 4 inches (10.2 cm) thick. Surface area where drinker sits should be smooth and level to provide a good seal. From the edge of the drinker, pad should slope about one-quarter inch per foot (about 1cm per 48 cm). The size of the pad is left to the user's discretion but we suggest you pour a pad large enough for livestock to stand on while drinking (about 19 inches (48 cm) beyond the edge of unit on all four sides). A rough broom finish provides better livestock footing. NOTE: The area where drinker sits should be smooth. A styrofoam barrier should be provided around the riser tile. Supply line should be at least 3/4 inch (1.9 cm) diameter. However, line should be sized to account for any pressure drop relating to distance. Water lines over 50 feet (15 meters) should be one inch (2.54 cm) or larger. Use of undersized supply line may cause loss of recovery capability.

### STEP 4: INSTALL HEATER ASSEMBLY - Review Exhibit I on page 6.

1. Install Ref. Nos. 18 and 19 1 1/2" x 12" PVC tube and 1 1/2" adapter into the threaded hole furthest from the access door. This hole is marked A in Exhibit I. The hole is engraved with a label that says 'heater' underneath the trough. Be sure to use Ref. No. 20 O-Ring.
2. Snap on Ref. No. 21 split tee or clip. This is used to help support the heater on the 12" tube. Rotate the clip so that it is on the side of the Ref. No. 18 12" tube (or 90 degrees to the wall of the drinker).
3. The plug end of your Ref. No. 22 C250 utility de-icer is threaded down through the Ref. No. 18 PVC tube and plugged into a receptacle in the cavity underneath the trough of the drinker. Hang the de-icer onto the Ref. No. 21 split tee and secure with Ref. No. 23 tywrap.

### STEP 5: INSTALL VALVE ASSEMBLY. Install water supply line and valve. See Exhibit I on page 6.

1. The threaded hole for water supply is closest to the access door and is engraved with a label that says 'water' both underneath the trough and in the trough also. This hole is labeled C in Exhibit I. Install Ref. No. 12 riser tube assembly into the threaded hole in the trough of the drinker. Be sure to use Ref. No. 13 O-Ring.
2. Glue Ref. No. 9 MACHINED adapter to the top of Ref. No. 11 supply tube.
3. Install supply tube through Ref. No. 12 riser tube assembly. Tighten with Ref. No. 10 slip joint nut. The slip joint nut should be centered on the MACHINED adapter. Tighten Ref. No. 8 3/4 elbow onto the Ref. No. 7 valve and then onto Ref. No. 9 machined adapter. Use Teflon tape or a thread compound. You may want to wait to install the float (Ref. No. 4) until the installation is complete. Glue Ref. No. 14 non-machined or standard adapter onto the bottom of the supply tube.
4. Install Ref. No. 16 1 1/2" plug into the center threaded hole. This hole is labeled with an engraving that says 'drain' underneath the drinker and is marked as B in Exhibit I. Again, use Teflon tape or a thread compound. The purpose of this hole is to give you an internal drain option. You would have to install a tile or make some other provision to drain the water away. Most operators use Ref. No. 15 rubber stopper, push it in from the outside and allow the drinker to drain onto the ground around the drinker when cleaning.

### STEP 6: MOUNT DRINKER TO PAD.

1. Slide Ref. No. 25 foam pipe insulation over your incoming water supply line making it at least even with the top of the riser tile or it can extend an inch or two (2-5 cm) up into the cavity of the drinker. Hold foam insulation in place at the top with Ref. No. 23 tywrap.
2. Stick Ref. No. 17 base seal to base bottom inside the anchor slots. You can also use a plumber's putty to seal the base.
3. Set the base of the drinker over your riser tile coming out of the ground and position base so that you have a convenient hookup to both your electrical and water supply lines.
4. Connect your incoming water supply line to Ref. No. 14 non-machined (standard) adapter. Use Teflon tape or a thread compound.
5. Make your electrical connection. In cold weather season, you should also plug in the furnished heat tape and wrap it around your water supply line underneath the drinker trough.
6. When you are comfortable with the positioning of your drinker relative to the water and electrical supply hookups, lag drinker to pad. **USE AN ANTISEIZE COMPOUND** (Permatex brand or equivalent) on the lag bolt threads and nuts.

### STEP 7: INSTALL FLOAT AND TURN ON WATER

1. Install Ref. No. 4 float. Adjust so that there is no interference with the heater assembly.
2. Turn on water and adjust float so that water fills the reservoir about 1 inch (2.54 cm) from the overflow of the drink opening—or as you desire. Check all connections to make sure there are no leaks.
3. **VALVE ADJUSTMENT:** All our drinkers are equipped with valves with interchangeable orifices when shipped. This dependable valve has served our customers since 1975. The standard valve for your unit normally operates on a range of 20 to 60 psi. When your drinker is installed on a gravity flow or low pressure system, you may adjust your valve for more water volume by using a larger orifice. If your drinker is installed on a high pressure water system (over 60 pounds) you may compensate for extra pressure by using a smaller orifice. For severe high pressure situations, you may need to install a pressure regulator.

### STEP 8: SPRING LOADED VALVE COVER (lid) - Review Exhibit F.

To lock the lid onto the base, place the lid into the body, aligning the stainless steel pegs on the lid with the tabs on the top surface of the base. With your 2 index fingers, depress the stainless steel pegs and push down on the lid. The pegs will snap into the holes in the tabs. To remove the lid, take most any instrument such as a screwdriver, end of a pliers handle, even a key. Depress the peg through one tab and pull up on that side of the lid so that the peg is not in the hole. Hold that side of the lid (so that the peg is not in the hole) while depressing the peg on the other side. The valve cover should pop up and off the base.

**VP VALVE CAPACITIES**  
**Gallons per Minute**  
**(Liters)**

	VP114	VP16	VP17
	5/32" Orifice	1/4" Orifice	3/8" Orifice
PS			
20	2.44 (9.2)	3.70 (14.0)	5.00 (18.9)
40	3.70 (14.0)	6.25 (23.7)	8.33 (31.5)
60	4.55 (17.2)	7.69 (29.1)	9.62 (36.4)
80	5.00 (18.9)	7.94 (30.0)	9.62 (36.4)

Model VP114 5/32 inch orifice comes standard with Model VP123 valve.

Ref No.	Part No.	Description	Qty
1	VP19	Power Link	1
2	VP110	Cam Link	1
3	VP11	Valve Body	1
4	VP111	Link Pin	2
5	VP18	Plunger	1
6	VP113	Diaphragm, Rubber	1
7	VP114	Orifice, 5/32	1
8	VP112	O Ring 5/8 x .103 Neoprene	1
9	VP13	Base 3/4 OD x 1/4 ID, Plastic	1
10	VP15	Assembly Nut	1
11	VP115*	Adjust Screw	1
12	VA225P*	Float Arm Plastic	1

**EXHIBIT E**

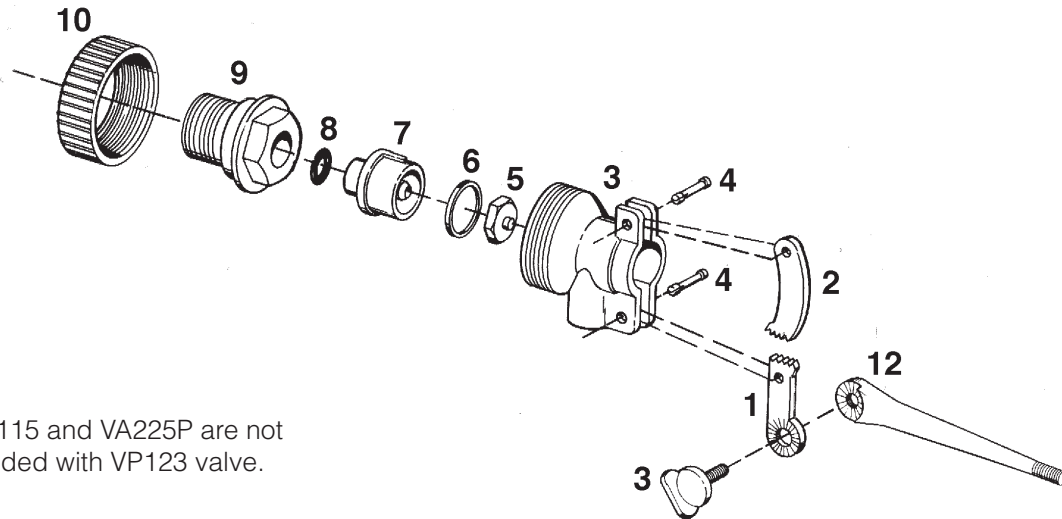

\* VP115 and VA225P are not included with VP123 valve.

**HEATER OPERATION:**

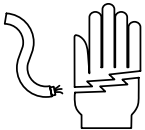

**DISCONTINUE ELECTRICAL SERVICE TO ELECTRIC SUPPLY LINE BEFORE REMOVING THE HEATER.**

Farm Innovators Model C250 Utility De-Icer standard specifications are 250 Watts / 120 VAC / 2.0 AMPS. The heat range is about 34° F to 45° F. The de-icer only works when the temperature approaches freezing. It is thermostatically controlled to turn on at freezing and to turn off when the temperature is above freezing.

If unit freezes in the drinker due to the loss of power, allow unit adequate time to melt itself free. Do not chop or cut at unit while plugged in.

Low voltage is a possible cause for failure or poor performance. Measure voltage at receptacle with unit energized. Voltage drop means wattage reduction. Extension cords cause voltage drop and are unsafe.

**IMPORTANT! DO NOT ALLOW DEPOSITS TO BUILD UP ON THE HEATING ELEMENT.** This can cause "hot spots" which is a primary reason of failure and voids the warranty. White vinegar or "Lime Away" can be used to clean the tubular element.

When taking unit out of service, disconnect power supply cord, remove unit from tank, clean element (see above), store indoors.

**ALSO, PLEASE NOTE:**

1. Do not energize the heater until the drinker is filled with water.
2. Do not operate the unit out of water (except to test - See No. 3 below.)
3. Here's how you can check to see if your heater is working --
  - a) Set unit in freezer for one hour or outside for one hour if temperature is below 35 degrees F.
  - b) Connect heater to an electrical source. Hold the heater by the cord set. Within seconds, the element should begin to heat. Listen for the thermostat to "click" off. Disconnect the unit. The unit is working properly.

Exhibit F  
Valve Cover Parts

Exhibit G  
Access Door Parts

Ref. No.	Part No.	Description	Qty.	Ref. No.	Part No.	Description	Qty.
A	OF572	#14575 SS Cotter Pin .094" Dia c 3/4"	2	E	OF543	Fillister Head Bolt, 1/4"	1
B	OF573	#14573 SS Cotter Pin, 4 1/2" L	2	G	VK17	Spring, SS	1
C	OF570	#14574 SS Washer .344" ID x .750" OD	2	F	OF541	Roll Pin, SS 1/8" x 1"	1
D	OF571	#14571 SS Spring .48" OD x 1 3/4" L	2				

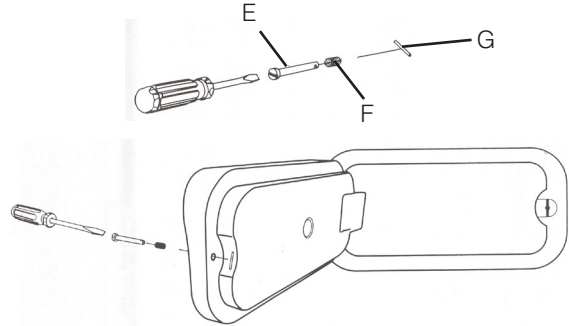
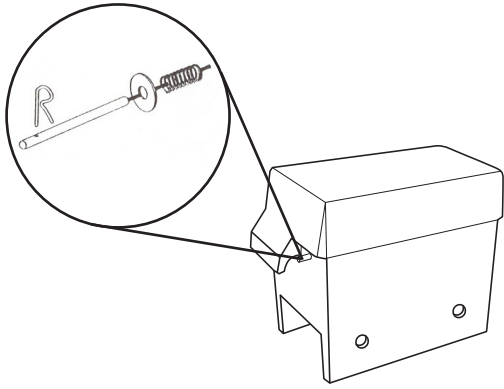

To open access door use a straight blade screwdriver. Turn Fillister Head Bolt one quarter turn and the bolt should pop out.

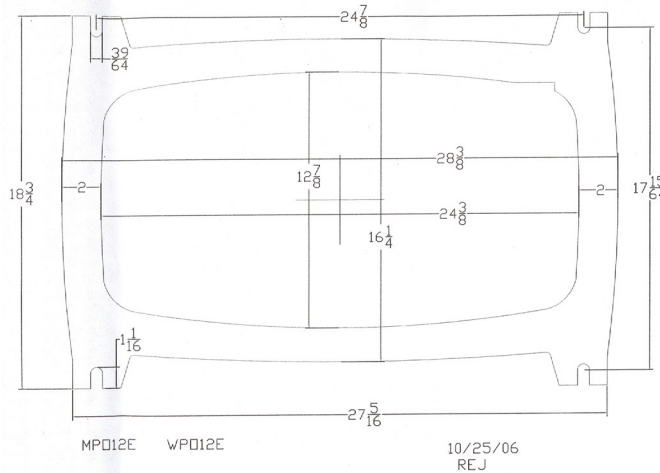

**EXHIBIT H**  
TOP DOWN VIEW OF WPO12/WPO12  
Base Dimensions in inches

### LIMITED WARRANTY

Our part no. OP284 C250 Utility Deicer (heater) and our DURAPRIDE Valve (including float arm, float and adjust screw) carry an 18 month limited warranty. All other components of Hawkeye Steel Products, Inc. Performance One E-Drinks are covered by a five year limited warranty. After the five year warranty period, all components, except valve and heater parts, are covered by an additional 6 year pro-rated warranty. Both warranty periods are from the date of purchase. Each drinker must be registered with Hawkeye Steel Products, Inc. on the card which accompanies each drinker. Warranted components should be returned to your dealer for shipment to our factory -- Highway 16 West, P.O. Box 2000, Houghton, IA 52631 USA, Fax 319-469-4402; 800-553-1791. Warranty is limited to the repair or replacement of components. The warranty does not cover removal or reinstallation; cost to transport and retrieve components for repair; damage or loss occurring during transport; damage due to foundation design; damage caused by natural or environmental conditions (acts of God); costs associated with loss of time and/or inconvenience or any other consequential damages; injury; lack of animal performance; loss of profit; life of property; malfunction resulting from misuse, improper installation, lack of maintenance (such as not periodically removing deposits on the deicer), unauthorized alteration, or negligence. All provisions stated on the back of Hawkeye Steel Products, Inc.'s invoice apply and Hawkeye Steel Products, Inc. assumes no consequential damages.

Exhibit I

